

# ICC-ES Evaluation Report

**ESR-3560**
*Reissued September 2015*
*This report is subject to renewal September 2017.*
[www.icc-es.org](http://www.icc-es.org) | (800) 423-6587 | (562) 699-0543

A Subsidiary of the International Code Council®

**DIVISION: 08 00 00—OPENINGS**  
**Section: 08 95 43—Vents/Foundation Flood Vents**

**REPORT HOLDER:**

**FLOOD FLAPS®**, LLC  
 2707 WATERPOINTE CIRCLE  
 MT. PLEASANT, SOUTH CAROLINA 29466  
 (843) 849-8031  
[www.floodflaps.com](http://www.floodflaps.com)  
[info@floodflaps.com](mailto:info@floodflaps.com)

**EVALUATION SUBJECT:**

**FLOOD FLAPS® FLOOD VENTS: MODELS FFWF12;  
 FFNF12; FFWF08; FFNF08; FFWF05; FFNF05**

**1.0 EVALUATION SCOPE**
**Compliance with the following codes:**

- 2012 and 2009 *International Building Code*® (IBC)
- 2012 and 2009 *International Residential Code*® (IRC)

**Properties evaluated:**

- Physical operation
- Water flow
- Weathering

**2.0 USES**

Flood Flaps® are used to provide for the equalization of hydrostatic flood forces on exterior walls.

**3.0 DESCRIPTION**
**3.1 General:**

Flood Flaps® flood vents are engineered mechanically operated flood vents (FVs) that automatically allow flood waters to enter and exit enclosed areas. The FVs are constructed of ABS plastic which serves as the FV's housing, and a front grill that contains an anodized metal screen imbedded in polypropylene plastic. On contact with rising flood water, the grill will disengage from its secured position, allowing flood water and debris to flow through in either direction.

The sealed series models contain two rubber flaps that close the FV to the passage of air when using with conditioned areas or sealed crawl spaces. In the same manner as the grill, the two rubber flaps are pushed open by water pressure, allowing water and debris to flow

through the FV in either direction. See Figure 1 for an illustration of the Flood Flaps® FV.

**3.2 Engineered Opening:**

The Flood Flaps® FVs comply with the design principle noted in Section 2.6.2.2 of ASCE/SEI 24 for a rate of rise and fall of 5 feet per hour (0.423 mm/s). In order to comply with the engineered opening requirement of ASCE/SEI 24, Flood Flaps® FVs must be installed in accordance with Section 4.0.

**3.3 Model Sizes:**

The Flood Flaps® FV model designations and sizes are as follows:

MODEL	WIDTH (in)	HIGHT (in)	DEPTH (in)
FFWF12 FFNF12	15 <sup>5</sup> / <sub>8</sub>	7 <sup>3</sup> / <sub>4</sub>	12
FFWF08 FFNF08	15 <sup>5</sup> / <sub>8</sub>	7 <sup>3</sup> / <sub>4</sub>	8
FFWF05 FFNF05	15 <sup>5</sup> / <sub>8</sub>	7 <sup>3</sup> / <sub>4</sub>	5

For **SI**: 1 inch = 25.4 mm.

The FFWF series include two rubber flaps for the prevention of air flow. The FFNF series omit the rubber flaps.

**3.4 Ventilation:**

Flood Flaps® FV models FFNF12, FFNF08, FFNF05, and FFNF02 have metal screens with 1/4 inch by 1/4 inch (6 mm by 6 mm) openings and provide 37 square inches of net free opening to supply natural ventilation for under-floor ventilation. Flood Flaps® FV models FFWF12, FFWF08, and FFWF05 have not been evaluated for use as openings for under-floor ventilation.

**4.0 DESIGN AND INSTALLATION**

Flood Flaps® FVs are designed to be installed into walls of existing or new construction. Installation of the FVs must be in accordance with the manufacturer's instructions, the applicable code and this report. Flood Flaps® FVs can be installed in wood, masonry and concrete walls up to a thickness of 12 inches (305 mm). In order to comply with the engineered opening design principle noted in Section 2.6.2.2 of ASCE/SEI 24, the Flood Flaps® FVs must be installed as follows:

- With a minimum of two openings on different sides of each enclosed area.

- With a minimum of one FV for every 220 square feet (20 m<sup>2</sup>) of enclosed area.
- Below the base flood elevation.
- With the bottom of the FV located a maximum of 12 inches (305 mm) above grade.

## 5.0 CONDITIONS OF USE

The Flood Flaps<sup>®</sup> flood vents described in this report comply with, or are suitable alternatives to what is specified in, those codes listed in Section 1.0 of this report, subject to the following conditions:

- 5.1 The Flood Flaps<sup>®</sup> FVs must be installed in accordance with this report, the applicable code and the manufacturer's installation instructions. In the event of a conflict, the instructions in this report govern.

- 5.2 The Flood Flaps<sup>®</sup> FVs must not be used in place of "breakaway walls" in coastal high hazard areas, but are permitted for use in conjunction with breakaway walls in other areas.

## 6.0 EVIDENCE SUBMITTED

Data in accordance with the ICC-ES Acceptance Criteria for Mechanically Operated Flood Vents (AC364), dated October 2013.

## 7.0 IDENTIFICATION

The Flood Flaps models recognized in this report are identified by a label bearing the manufacturer's name, the model number, and the evaluation report number (ESR-3560).

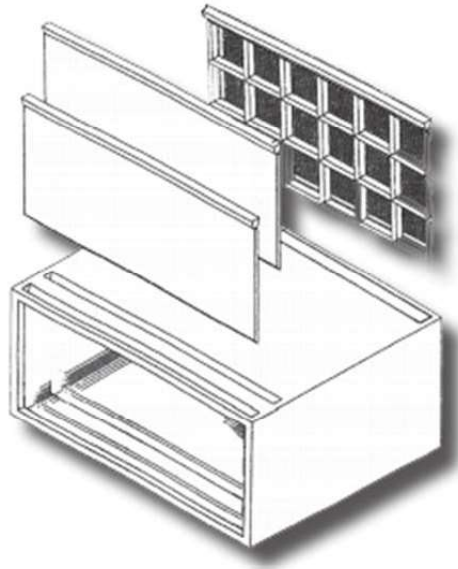

FIGURE 1—FLOOD FLAPS<sup>®</sup> FLOOD VENT